

LUCAS MILL

WORLD LEADING
PORTABLE SAWMILLS

Portability: Easy to transport and set up on-site.

Versatility: Cuts logs of all sizes.

Efficiency: Fast, accurate, low waste.

Ease of Use: Simple, adjustable operation.

Durability: Built tough for heavy use.

Distributor for North America:

The logo for Bailey's is written in a stylized, cursive red font with a white outline and a registered trademark symbol.

BAILEY'S OUTDOOR POWER EQUIPMENT

1222 COMMERCE AVE, SUITE D,
WOODLAND, CA, UNITED STATES, 95776

888-465-8227

sales@baileysonline.com

90 Days — No Payments

Start milling before your first payment is due.

\$0 Down Available

Preserve your Cash

Extended Terms

Spread payments over longer terms to fit your cash flow.

Competitive Rates

Click or scan
to learn more:



MODEL SPECIFICATIONS

MODEL	ENGINE	TRANSMISSION	BLADES	CUTTING LENGTH	CUTTING DIMENSIONS	MAJOR COMPONENTS WEIGHT		
						PWR HEAD	RAILS	END-FRAMES
4-6	6 H/P manual start Honda, 4-6 petrol	4" centrifugal clutch 1 x SPA 757 belt 0.96" (25mm) shafts 1 piece hub shaft assembly	3 tooth TCT 0.09" plate 0.16" kerf	Up to 11' - 9" (3.6m)	Up to 4 $\frac{1}{8}$ " X 4 $\frac{1}{8}$ " (106mm x 106mm) Double cut up to 4 $\frac{1}{8}$ " x 8 $\frac{1}{4}$ " (106mm x 212mm)	187 lbs (85kg)	17.6 lbs (28kg)	136.6 lbs (62kg)
6-14	14H/P manual start, V-twin 6-14 Vanguard, petrol	4" centrifugal clutch 3 x SPA 875 belts 0.96" (25mm) shafts 1 piece hub shaft assembly	5 tooth TCT 0.10" plate 0.19" kerf	Up to 14' - 9" (4.5m) in standard form	Up to 6 $\frac{1}{4}$ " X 4 $\frac{1}{4}$ " (160mm x 160mm) Double cut up to 6 $\frac{1}{4}$ " x 12 $\frac{1}{2}$ " (160mm x 320mm)	260 lbs (118kg)	134 lbs (61kg)	167.5 lbs (76kg)
6-18	18 H/P manual & electric start, 6-18 V-twin Vanguard, petrol	4" centrifugal clutch 3 x SPA 875 belts 0.96" (25mm) shafts 1 piece hub shaft assembly	5 tooth TCT 0.10" plate 0.19" kerf	Up to 20' (6.1m) in standard form	Up to 6 $\frac{1}{4}$ " x 4 $\frac{1}{4}$ " (160mm x 160mm) Double cut up to 6 $\frac{1}{4}$ " x 12 $\frac{1}{2}$ " (160mm x 320mm)	288 lbs (131kg)	134 lbs (61kg)	167.5 lbs (76kg)
7-23	23 H/P manual & electric start, 7-23 V-twin Vanguard, petrol	5" centrifugal clutch 2 x SPAX 1000 belts 1.08" (30mm) shafts 1 piece hub shaft assembly	5 tooth TCT 0.12" plate 0.21" kerf	Up to 20' (6.1m) in standard form	Up to 7 $\frac{7}{8}$ " x 7 $\frac{7}{8}$ " (200mm x 200mm) Double cut up to 7 $\frac{7}{8}$ " x 15 $\frac{3}{4}$ " (200mm x 400mm)	315 lbs (343kg)	134 lbs (61kg)	178.5 lbs (81kg)
8-30	EFI electric 8-30 start, V-twin Kohler, petrol	5" centrifugal clutch 3 x SPAX 1000 belts 1.08" (30mm) shafts 1 piece hub shaft assembly	5 tooth TCT 0.12" plate 0.22" kerf	Up to 20' (6.1m) in standard form	Up to 8 $\frac{1}{8}$ " x 8 $\frac{1}{8}$ " (215mm x 215mm) Double cut up to 8 $\frac{1}{2}$ " x 17" (215mm x 430mm)	370lbs (168kg)	134 lbs (61kg)	178.5 lbs (81kg)
10-30	EFI electric 10-30 start, V-twin Kohler, petrol	5" centrifugal clutch 3 x SPAX 1030 belts 1.08" (30mm) shafts 1 piece hub shaft assembly	5 tooth TCT 0.12" plate 0.24" kerf	Up to 20' (6.1m) in standard form	Up to 10" x 10" (254mm x 254mm) Double cut up to 10" x 20" (254mm x 508mm)	388 lbs (176kg)	134 lbs (61kg)	178.5 lbs (81kg)
A 15H/P, 3-Phase, 400V 50hz electric motor option is available for the models 8-30 & 10-30								
Dedicated Slabber DSM 23	23 H/P vertical shaft electric start, V-twin Vanguard, petrol	5" centrifugal clutch 2 x A24 belts	Slabbing bar with harvester sprocket	Up to 20' (6.1m) in standard form	Slabbing width: 5' (1.5m) standard 6'-4" (1.9m) option available	275 lbs (125kg)	134 lbs (61kg)	178.5 lbs (81kg)
Super Slabber DSSM 23	23 H/P vertical shaft electric start, V-twin Vanguard, petrol	5" centrifugal clutch 2 x A24 belts	Slabbing bar with harvester sprocket	Up to 20' (6.1m) in standard form	Slabbing width: 9' (2.7m)	551 lbs (250kg)	134 lbs (61kg)	178.5 lbs (81kg)

PLEASE NOTE: THESE MODEL SPECIFICATIONS ARE SUBJECT TO CHANGE ANYTIME WITHOUT NOTICE

Click or Scan



888-465-8227
sales@baileysonline.com

PRICE LIST

Click or Scan



- **90 Days — No Payments**
- **\$0 Down Available**
- **Extended Terms**
- **Competitive Rates**

MODEL 6-16

Engine: 16HP, V-twin, Vanguard, Manual Start
Cut: 6¼" (160mm) x 6¼" (160mm)
Log: Length – 14.9' (4.5m), Diameter – 4.4' (1.35m)
Blades: 2 **Side Shift Winder:** Optional

\$13,495

MODEL 6-18

Engine: 18HP, V-twin, Vanguard, Electric & Manual Start
Cut: 6¼" (160mm) x 6¼" (160mm)
Log: Length – 20' (6.1m), Diameter – 4.4' (1.35m)
Blades: 4 **Side Shift Winder:** Standard

\$15,495

MODEL 7-23

Engine: 23HP, V-Twin, Vanguard, Electric & Manual Start
Cut: 7⅞" (200mm) x 7⅞" (200mm)
Log: Length – 20' (6.1m), Diameter – 4.4' (1.35m)
Blades: 4 **Side Shift Winder:** Standard

\$17,495

MODEL 8-30

Engine: EFI V-twin, Kohler, Electric Start
Cut: 8½" (215mm) x 8½" (215mm)
Log: Length – 20' (6.1m), Diameter – 4.4' (1.35m)
Blades: 4 **Side Shift Winder:** Standard

\$20,495

MODEL 10-30

Engine: EFI V-twin, Kohler, Electric Start
Cut: 10" (254mm) x 10" (254mm)
Log: Length – 20' (6.1m), Diameter – 4.4' (1.35m)
Blades: 4
Side Shift Winder: Standard

\$21,495

DEDICATED SLABBER

DSM 23 15

Dedicated Slabber (60" Maximum cut)
Engine: Briggs 23HP Electric / Manual Start
Cut Width: 5' (1.5m), Length: 20' (6.3m), Depth: 19.7" (500mm)

\$13,495

DSM 23 19

Dedicated Slabber (76" Maximum cut)
Engine: Briggs 23HP Electric / Manual Start
Cut Width: 6.3' (1.9m), Length: 20' (6.3m), Depth: 19.7" (500mm)

\$14,495

DSM 23 27

Super Slabber (108" Maximum cut)
Engine: Briggs 23HP Electric / Manual Start
Cut Width: 9' (2.7m), Length: 20' (6.1m), Depth: 10.5" (271mm)

\$19,995

DST 23 15

Dedicated Slabber Trolley only **Engine:** Briggs 23HP Electric / Manual Start
Cut Width: 5' (1.5m), Depth: 19.7" (500mm) **Trolley Weight:** 300lbs (135kg)

\$10,495

DST 23 19

Dedicated Slabber Trolley only **Engine:** Briggs 23HP Electric / Manual Start
Cut Width: 6.3' (1.9m), Depth: 19.7" (500mm) **Trolley Weight:** 300lbs (135kg)

\$10,995

ALL MACHINES ARE PROVIDED WITH A 3-YEAR WARRANTY AGAINST FAULTY PARTS AND WORKMANSHIP.

All circular blade Lucas Mills are supplied with lightweight aluminum rails, end frames, toolbox and diamond wheel mini grinder with customized bracket for blade sharpening.

Click or Scan



888-465-8227
sales@baileysonline.com

PRICE LIST

Click or Scan



- **90 Days — No Payments**
- **\$0 Down Available**
- **Extended Terms**
- **Competitive Rates**

SLABBER ATTACHMENT

This attachment is available to suit any Lucas Mill. After removing the sawblade the attachment is mounted to the output shaft using a drive hub and sprocket.

Package includes slabbing bar, 5-skip chain, drive hub & sprocket, file & guide and oiler bottle.

Model 6: Cut Width 4', Depth 6" / Model 7: Cut Width 5', Depth 7.5" / Model 8/10: Cut Width 5', Depth 9"

\$2,095.99

TRACK OPTION

Track Options Not available for Model 4-6.

6'6" Extension Kit

\$1,095.99

OPTIONAL ATTACHMENTS

Planing Disc: Ideal for achieving a superior finish on boards and slabs. Follow with the Sanding Disc for an even smoother finish.

6" \$1,295.99
7,8,10" \$1,495.99

Sanding Disc: Achieve a beautiful smooth finish and add value to your slabs. Includes 4 sandpaper grades. mooth finish, includes 4 sandpaper grades

\$1,195.99

Chain Sharpening Jig: FA must have for Slabber operators, this jig facilitates easy and accurate chain maintenance.

\$495.99

Opteco Re-Tipping Jig Kit: Re-tip sawblades accurately and economically with this handy jig kit.

\$845.99

Log Chocks: Secure logs on bearers, set of 4

\$395.99

Blade Cases: Protect blades in storage & transit.

6" \$79.99 7,8" \$84.99 10" \$89.99

Additional Sawblades: Price per sawblade

6" \$199.99 7" \$219.99
8" \$249.99 10" \$349.99

ALL MACHINES ARE PROVIDED WITH A 3-YEAR WARRANTY AGAINST FAULTY PARTS AND WORKMANSHIP.

All circular blade Lucas Mills are supplied with lightweight aluminum rails, end frames, toolbox and diamond wheel mini grinder with customized bracket for blade sharpening.

Click or Scan



888-465-8227
sales@baileysonline.com

SET-UP INSTRUCTIONS

1) PUT THE TWO END FRAMES TOGETHER.

- A) SET THE BOTTOM END FRAME PIPES ON THE GROUND ABOUT 18' APART.
- B) ATTACH THE STABILIZER POST IN FIRST AND USE THE STABILIZER ARM TO HOLD IT UPRIGHT. PUSH THE SADDLE BRACKET ALL THE WAY DOWN.
- C) ATTACH THE CRANK POST IN NEXT AND CRANK THE SADDLE BRACKET DOWN AS FAR AS IT WILL GO.
- D) SLIP IN THE TOP END FRAME PIPE. ATTACH THE LYNCH PIN INTO THE STABILIZER IDE FIRST AND THE CRANKSIDE LYNCH PIN IN LAST (THIS MAKES IT EASIER TO LINE UP THE LYNCH PIN HOLES)

2) SET THE END FRAMES AT A MAX OF 18' APART

3) SET THE 20' RAILS ONTO THE SADDLE BRACKETS AND CLAMP THEM DOWN

(WHEN THE (BLACK) CAM LOCKS ARE LOCKED DOWN ON THE RAILS, THIS WILL HOLD YOUR MILL UPRIGHT WITHOUT THE USE OF THE STABILIZER ARMS.)

4) MAKE THE RAILS PARALLEL ** VERY IMPORTANT **

- A) SET THE BOTTOM END FRAME PIPES ON THE GROUND ABOUT 18' APART.
- B) ATTACH THE STABILIZER POST IN FIRST AND USE THE STABILIZER ARM TO HOLD IT UPRIGHT. PUSH THE SADDLE BRACKET ALL THE WAY DOWN.
- C) ATTACH THE CRANK POST IN NEXT AND CRANK THE SADDLE BRACKET DOWN AS FAR AS IT WILL GO.
- D) SLIP IN THE TOP END FRAME PIPE. ATTACH THE LYNCH PIN INTO THE STABILIZER IDE FIRST AND THE CRANKSIDE LYNCH PIN IN LAST (THIS MAKES IT EASIER TO LINE UP THE LYNCH PIN HOLES)

TRACKS MUST BE PARALLEL



HINT: ALOT OF PEOPLE WILL BRING A LEVEL TO THE JOBSITE TO TRY TO MAKE THE RAILS EVEN. THIS IS NOT THE BEST WAY TO DO IT. FIRST OF ALL, THE RAILS ARE SET TO RUN WITH THE TAPER OF THE LOG, SO A LEVEL DOESN'T NECESSARILY MAKE THE RAILS PARALLEL TO EACH OTHER. THIS IS BEST ACHIEVED BY STANDING APPROXIMATELY TWENTY FEET OFF TO THE SIDE, CLOSING ONE EYE AND SIGHTING FROM ONE END TO THE OTHER. IF ONE CORNER IS LOWER THAN THE REST, SIMPLY BLOCK UP THE LOW CORNER UNTIL THE RAILS ARE PARALLEL TO EACH OTHER AS SHOWN ABOVE. THE FLATTER THE PLANE, THE SMOOTHER THE MILL CUTS THROUGH THE LOG.

Click or Scan



LUCAS MILL
WORLD LEADING
PORTABLE SAWMILLS

Bailey's

888-465-8227

sales@baileysonline.com

SET-UP INSTRUCTIONS

5) SQUARING UP THE FRAME

- ROLL THE CARRIAGE ONTO THE TRACKS AND CRANK IT UP ENOUGH TO GET THE WHEELS OFF.
- USING THE PUSH BAR AS A REFERENCE, PUSH THE CARRIAGE PAST THE FIRST END FRAME. IF IT ROLLS PAST BOTH POSTS (CRANK SIDE AND STABILIZER SIDE) AT THE SAME TIME, LOCK THE CAMLOCKS SECURELY. IF NOT, MAKE IT SO.
- ROLL THE CARRIAGE DOWN TO THE OTHER END FRAME AND REPEAT THE PROCESS.
- THIS WILL ENSURE THAT YOUR FRAMEWORK IS SQUARED UP AND READY TO GO.

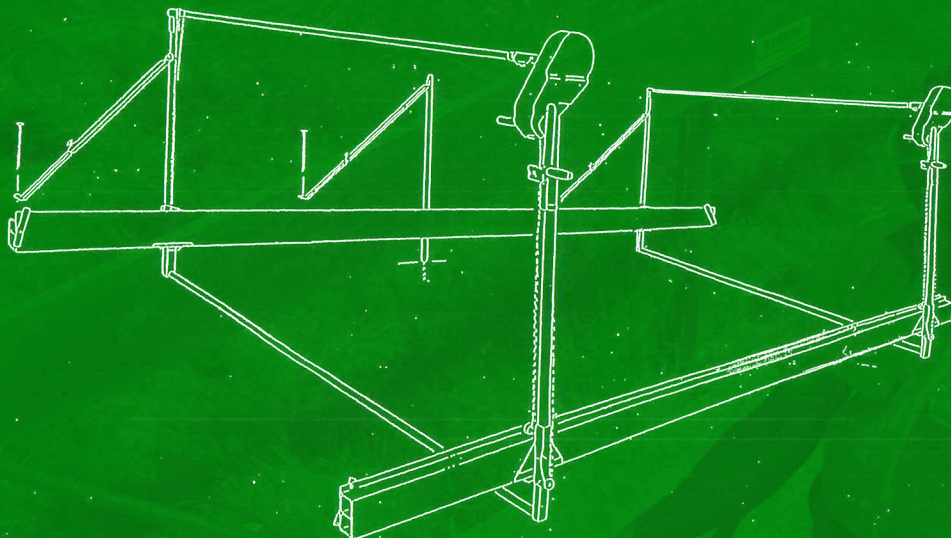

6) SLIDE YOUR TWO WOODEN BUNKS IN BETWEEN THE END FRAMES ON THE CRANK SIDE.

- 10' - 12' LONG BUNKS ARE USUALLY SUFFICIENT TO ACCOMMODATE A LOG IN BETWEEN THE RAILS AND A COUPLE ON THE OUTSIDE (DECK) READY TO ROLL IN. CUT LONGER ONES IF NECESSARY TO SUIT YOUR NEEDS.
- CUT A NOTCH APPROXIMATELY 10" FROM THE END OF THE BUNK AROUND 6" WIDE AND A COUPLE OF INCHES DEEP FOR THE CUTTING LOG TO SIT IN.

KEEP BOTH NOTCHES THE SAME DISTANCE TO THE ALUMINUM RAIL AS TO ASSURE THAT WHEN THE LOG IS ROLLED IN, THAT IT IS SITTING PARALLEL WITH THE RAILS.

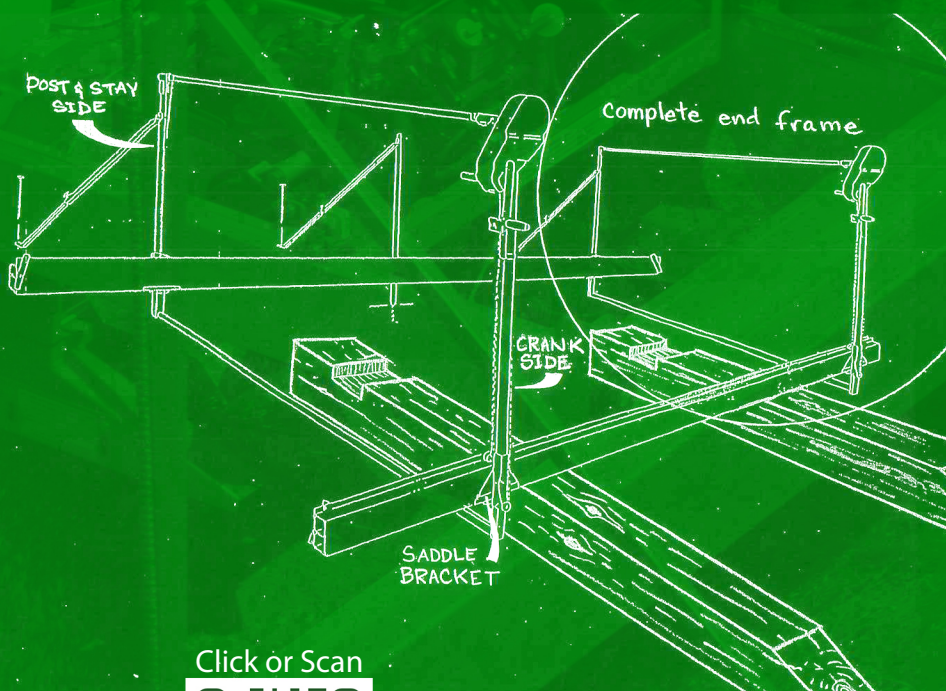

Click or Scan



LUCAS MILL
WORLD LEADING
PORTABLE SAWMILLS

Bailey's

888-465-8227

sales@baileysonline.com

SET-UP INSTRUCTIONS

7) ROLL A LOG IN BETWEEN THE RAILS:

- A) DROP THE LOG INTO THE PRE-CUT NOTCHES.
 - B) SLIP A WOODEN WEDGE ON ALL FOUR CORNERS OF THE LOG (ON THE BUNKS) TO SECURE THE LOG IN PLACE. USE A MALLOT OR AXE TO POUND THE WEDGES IN.
 - C) ROLL THE CARRIAGE FROM ONE END TO THE OTHER TO INSURE IT DOESN'T BUMP INTO THE LOG.
 - D) STARTING AT ONE END OF THE LOG, USE A TAPE MEASURER AND MEASURE FROM THE CENTER OF THE LOG TO THE BOTTOM OF THE ALUMINUM CARRIAGE FRAME.
 - E) ROLL DOWN TO THE OTHER END OF THE LOG AND CRANK THE MILL CARRIAGE UP OR DOWN TO GET THE SAME MEASUREMENT THAT YOU GOT ON THE FIRST END.
- (THIS STEP ALLOWS YOU TO GET THE MOST LUMBER OUT OF THE LOG WITH BETTER GRADE RECOVERY AND OVER-RUN)

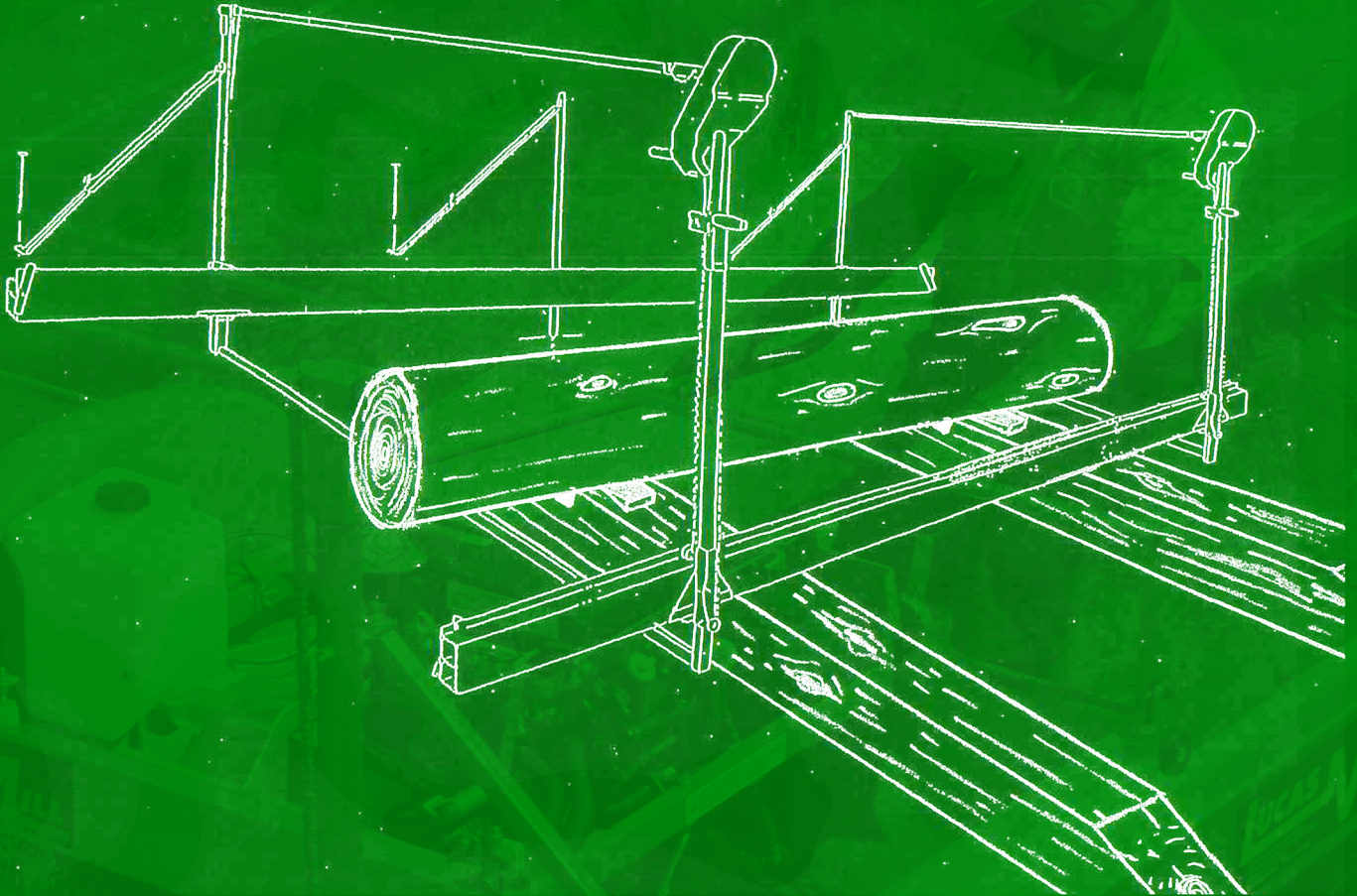

8) LOWER BOTH ENDS IN EQUAL INCREMENTS UNTIL YOU SLICE IN JUST DEEP ENOUGH TO GET A WIDE ENOUGH SURFACE TO MAKE AT LEAST ONE BOARD ON YOUR NEXT DROP

Click or Scan



LUCAS MILL
WORLD LEADING
PORTABLE SAWMILLS

Bailey's

888-465-8227
sales@baileysonline.com

SET-UP INSTRUCTIONS

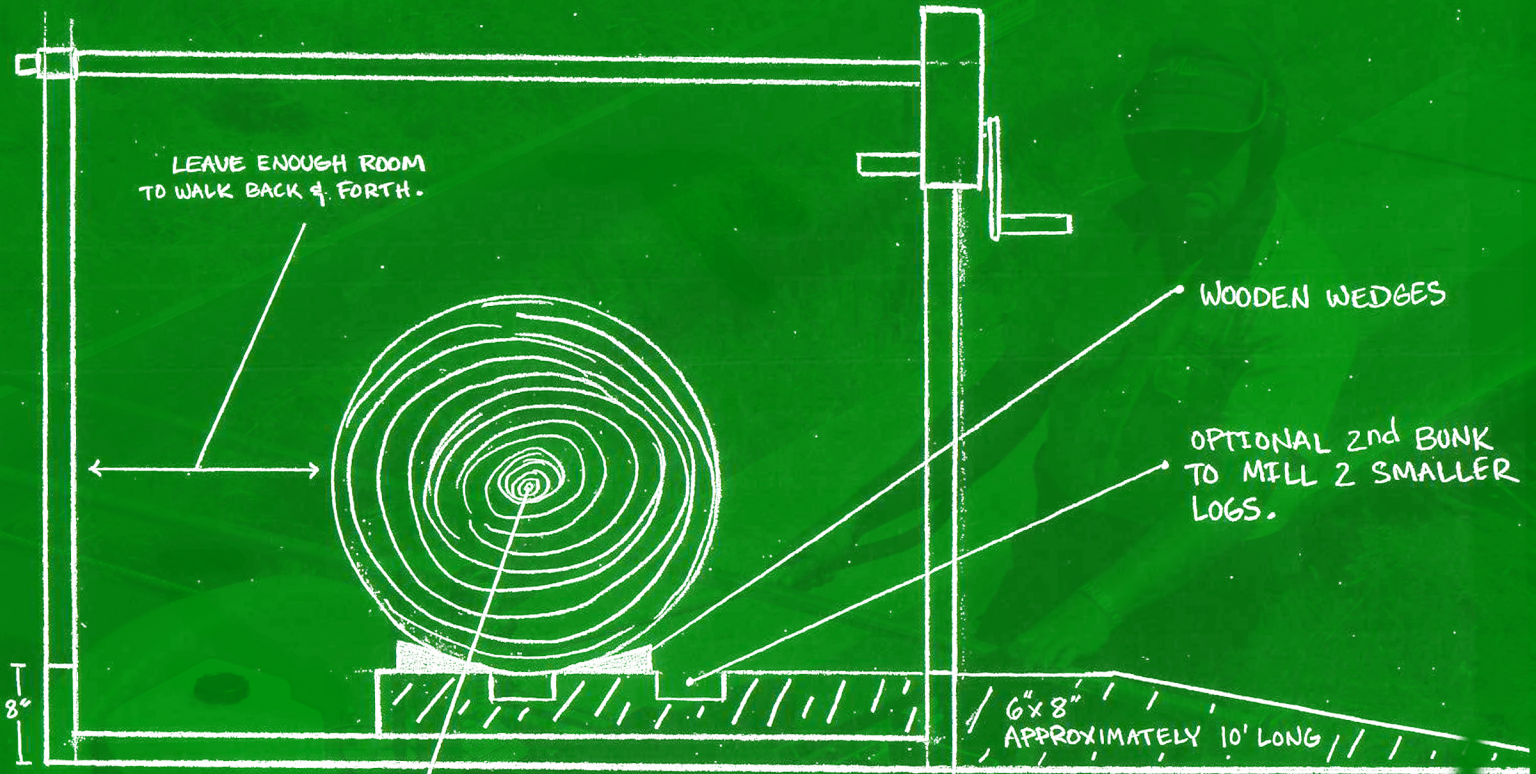

IF YOU ARE ROTATING THE POWERHEAD TO CUT THE WIDER BOARDS, CENTER THE LOG AS SHOWN. IF NOT, SET THE LOG OFF CENTER. (→)

Click or Scan



LUCAS MILL
WORLD LEADING
PORTABLE SAWMILLS

Bailey's

888-465-8227
sales@baileysonline.com

SET-UP INSTRUCTIONS

QUARTER SAWING WITH THE LUCAS MILL

Of special interest to the miller is the fact that the Lucas Mill can quarter saw without any turning of the log or material. Quarter sawn boards (vertical grain, see fig.3) are more valuable and in higher demand than flat sawn boards (fig.4), particularly with hardwoods. This is also true for most wood that is destined to be used for finish work, furniture and manufacture of doors and windows. Generally quarter sawing a log will give a considerably greater economic return than if the same log were plain sawn.

Because the unique swing blade of the mill allows a board to be cut either horizontally or vertically quarter sawing is easily achieved with the Lucas Mill with no extra effort.

Figure 2 shows how a log would normally be sawn using the Lucas Mill.

Figure 1 shows how the same log could be cut if the miller required quarter sawn lumber.

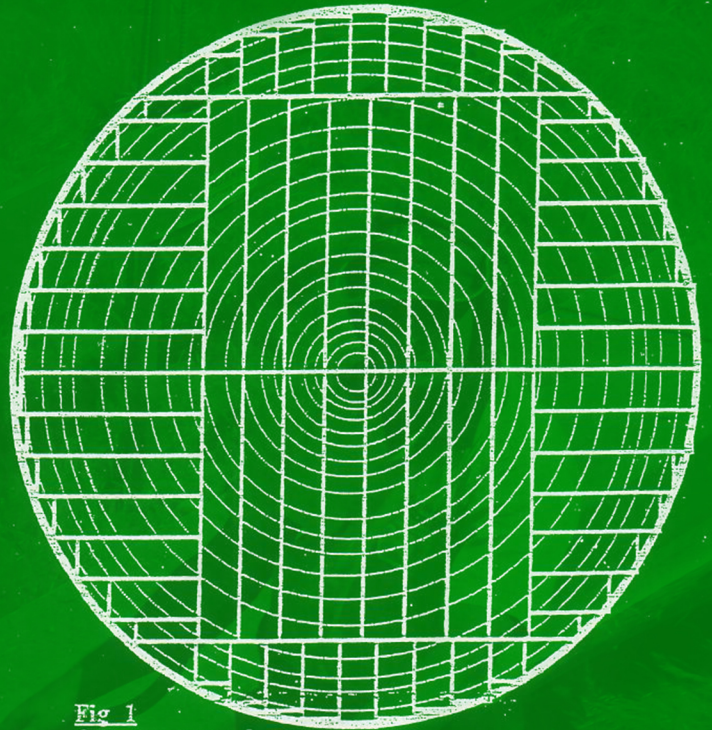

Fig 1
Quarter sawn log

End view of boards showing grain

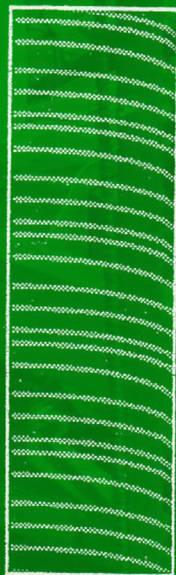

Fig.3
Quarter
sawn board

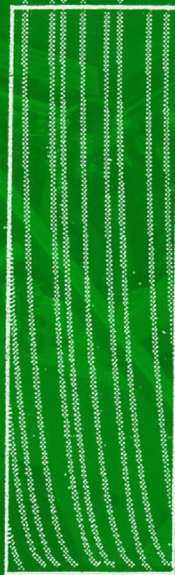

Fig. 4
flat sawn
board

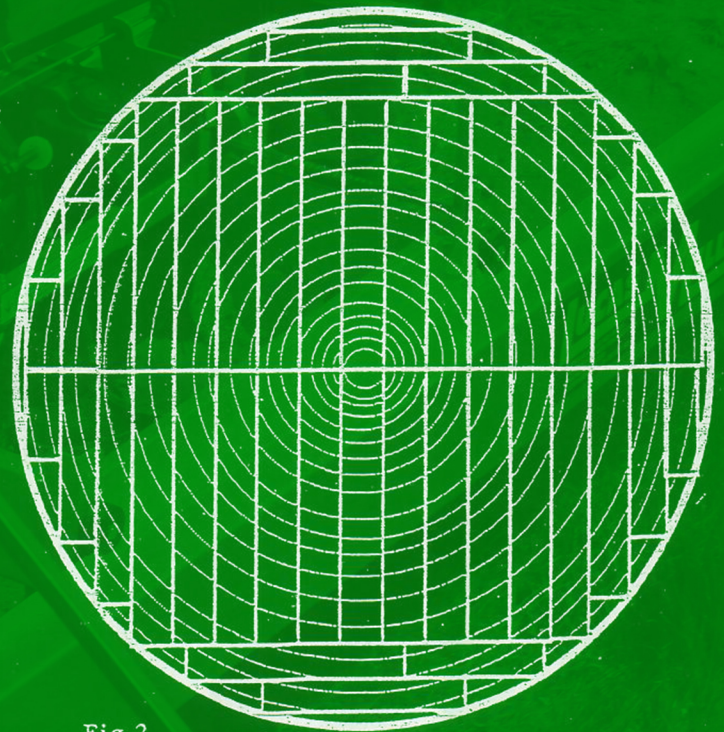

Fig.2
Normally sawn log

Click or Scan



LUCAS MILL
WORLD LEADING
PORTABLE SAWMILLS

Bailey's

888-465-8227
sales@baileysonline.com